



# **SERIAL DATA LINKS... BY RADIO**



***ELPRO 405U***

# Wireless serial links... RS232 or RS485

The ELPRO 405U radio modem module provides RS232 or RS485 connections by radio. It can be used instead of serial cable to link PLC's, dataloggers, supervisory computers and intelligent transducers.

The 405U has been designed to be easy to use and simple to install. It uses a low power UHF radio which does not require a radio licence\*. The module is fully integrated with radio, power supply, serial ports and microprocessor controller housed in a strong industrial aluminium case.

## Simple and Reliable

The 405U includes a radio transceiver, allowing communications in both directions, so the modules can check and control the transfer of information.

The 405U is suitable for both simple and complex systems. It can operate in a transparent mode, where the host devices provide error checking and communications control. For less intelligent host devices, the 405U can provide the addressing, error checking and control of communications. The 405U can also accept Hayes compatible commands for selective addressing.

## High Speed Wireless Data

Host devices can connect to the 405U via RS232 or RS485 serial ports, at data rates up to 38.4Kb. The 405U has two internal buffers of 8Kbytes and the radio can transmit data packages configurable up to 520 bytes, at speeds configurable up to 9600 bits/sec. The 405U radio modem is both low cost and very flexible.

## Radio Communications

The 405U operates on several UHF radio bands. Most countries provide low power licence-free channels for use without the need for an individual radio licence.

The 405U has been designed to operate reliably on an open licence-free channel with other users.

The expected radio range of the 405U is up to 10km(500mW) "line of sight" at 4800 bits/sec. The 405U module may also be configured to act as an intermediate repeater to provide longer radio paths. Up to five repeater modules may be configured for each link.

The transmission rate of the 405U radio may be configured between 1200 and 9600 bits/sec, half-duplex.

## RS232/485

The 405U connects to host devices using RS232 full duplex or RS485 half duplex. The RS232 connection provides standard CTS/RTS control, with the 405U module operating as a DCE device. The CTS/RTS signals may be configured to reflect the status of the 405U input buffer, or to reflect the CTS/RTS signals at the remote module.

The RS485 connection is a industry standard half-duplex twisted pair mulitdrop connection. Only one serial connection (RS232 or RS485) can be supported at each module, however different types of serial data can be connected to different modules in the same system.

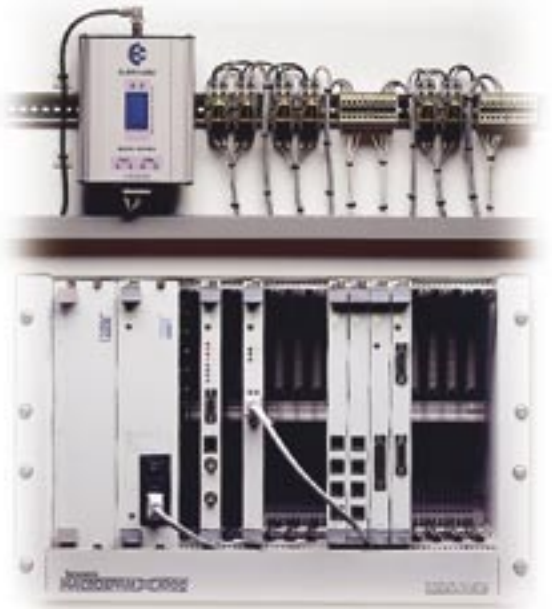

The 405U accepts data at standard rates between 75 and 38400 baud. It may be configured to accept 10-bit or 11-bit characters, with 7 or 8 data bits, even/odd/no parity, and 1 or 2 start and stop bits.

The 405U will connect to almost any host device!

*\*dependant on the radio regulations in each country*



# ELPRO 405U Radio Modem

## Configuration

The 405U module may be configured to operate in two different modes, to suit the type of host device. In each mode, data is sent in packets of up to 520 bytes, with a superimposed "system address". Only a module with the same system address will accept data from another module - this avoids cross-talk between systems operating in the same radio range.

Modules may be configured using on-board miniature switches.

Some parameters may be configured by the host device using standard Hayes codes.

## Transparent Mode

Transparent mode is suitable for host devices which provide their own data checking and control the flow of data. As data is received at the serial port, it is transmitted by radio and re-created at the serial port of all other modules with the same system address. There is no error checking carried out by the 405U modules and modules are not individually addressed – this is performed by the host devices. Modules listen to the radio channel and hold off transmitting until the channel is clear, apart from this there is no other transmission delay.

Transparent mode is suitable for PLC networks, or for a broadcast system where the same serial data is to be sent to multiple devices.

In transparent mode, one repeater may be configured – the repeater will re-transmit any radio message it receives.

## Controlled Mode

In controlled mode, each module is configured with a unit address, and the 405U modules perform error checking and acknowledgments.

If a message is corrupted during the radio transmission, the source module will re-transmit the data up to four times until the data is received correctly. If reliable radio communications cannot be achieved, a communications failure output is provided as a discrete signal. Controlled mode is suitable for host devices such as dataloggers or intelligent transducers which do not carry out error checking or control the flow of data.

In controlled mode, up to five intermediate repeaters may be configured in any one link.

Destination addresses, and repeater messages may be preset using the configuration switches on the module, or they may be set from the host device using standard Hayes AT codes. This type of system would be suitable for a master device (such as a PC) polling several slave devices (for example, dataloggers) to download information.

## Power Supply

The 405U module may be powered from either a 12 VDC or 24 VDC power supply.

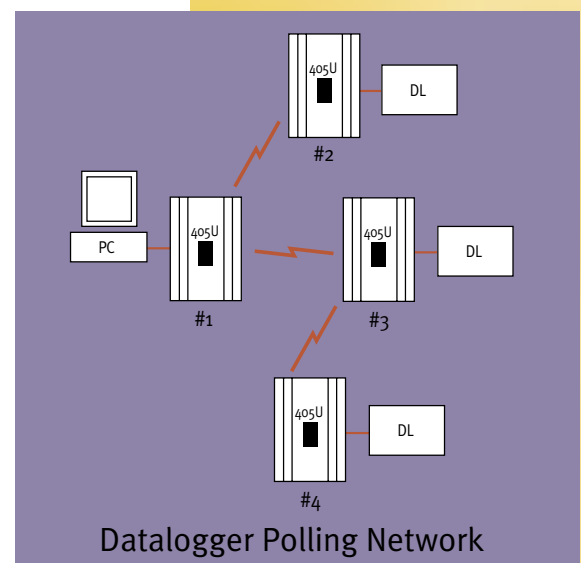
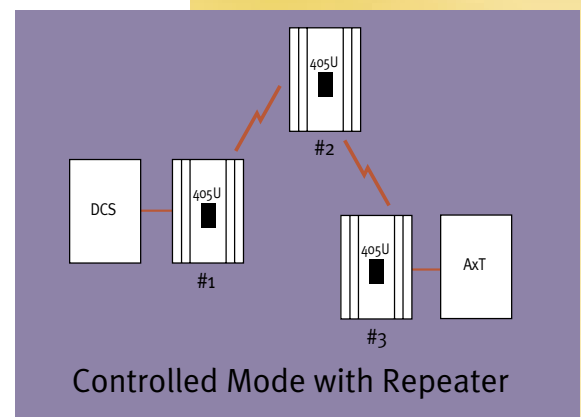
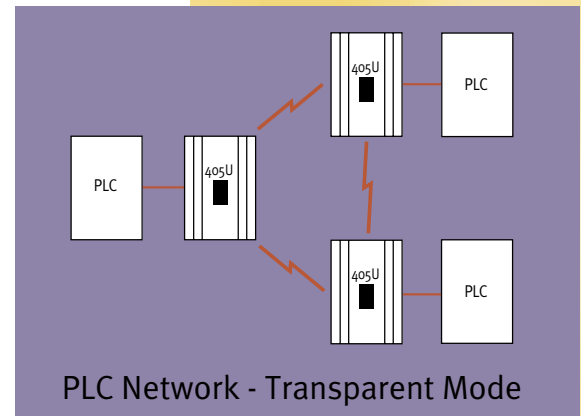

**Powerful, flexible, easy to use...**

# Specifications

## Power Supply

Normal supply 11-15 VDC. Alternate supply 18-28 VDC.  
Current normal 155mA (@12V) or 100mA (@24V)  
During transmit 500mA (12V) for 500mW  
1A (12V) for 5W

## General

Environmental -20 to 60 degC. 0 - 99 %RH.  
EMC Compliant 89/336/EEC, EN55022, EN55082-1, AS3548, IEC 60950.  
Housing, extruded aluminium case 130 x 185 x 60 mm DIN rail mounting, removable terminal blocks for ease of module replacement, terminals suitable for 2.5sqmm conductors.  
LED indication for unit OK, radio TX and RX, serial TX and RX, DCD (comms OK).

## Serial Port

Standard data rates 75, 150, 300, 600, 1200, 2400, 4800, 9600, 19200 and 38400 baud.  
RS232 and RS485 standard interface connections provided, each connected to the same serial port. Serial interfaces are asynchronous non-return-zero (NRZ) format.  
The following characters are supported (selectable) - 7 data bits, even or odd parity, 1 start bit, 1 or 2 stop bits; 7 data bits, no parity, 1 start bit, 2 stop bits; 8 data bits, even or odd or no parity, 1 start bit, 1 stop bit – the same type of character is created at the output.  
RS232 connection provides full duplex operation as a DCE device with RTS/CTS hardware handshaking – standard D9 connector.  
RS485 connection provides half duplex operation for twisted-pair multidrop networks.  
Terminal connectors provided for RS485.

## Radio Transceiver

Single channel, synthesised, direct frequency modulation, data rate configurable 1200, 2400, 4800 or 9600 bits/sec using four level DFSK.  
Frequency 405 – 490 MHz, 12.5KHz channel. Stability  $\pm 1.0$ KHz  
Transmit power 10-500mW  
Frequency 220 – 235MHz, 25 KHz Channel. Transmit power 5W (9600 baud not available)  
Conforms to ETS 300 220-1, MPT1329, AS4268.2  
Expected line-of-sight range (@4800 bits/sec) – 1.5km(10mW), 5km(100mW), 10km(500mW), 30km (5W).



Available from:

**EDAC Electronics Australia P/L**  
Suite 6, 173 Boronia Road  
Boronia, Victoria 3155, Australia  
**Phone: + 61 3 9762 6244**  
Fax: + 61 3 9762 6255  
Sales Director: billk@edac.com.au  
Technical Sales: markb@edac.com.au  
www.edac.com.au

Range may be extended by up to five intermediate repeaters (controlled mode) or one repeater (transparent mode).  
Aerial connection is BNC coaxial and protected by an internal gas discharge surge arrester.

## Data Transmission

**Transparent mode:** Data is transmitted in packets of up to 520 bytes with a system address. Data transmission begins as soon as serial data is received. For RS232, DCD signal is always high, and CTS is high while there is space in the input buffer. All modules, with correct system address, which receive the data packets output the data without error checking.  
**Controlled mode:** Data is transmitted in packets of up to 520 bytes (configurable), with a system address, source address, destination address, up to five intermediate repeater addresses, and a 16 bit CRC error check. If the packet is received with a correct error check, only the destination module will output the data and will also return an ACK transmission. If the source module does not receive the ACK, it will retry a further four times before resetting the DCD output. For RS232, the CTS signal is high if there is room in the input buffer. Destination and repeater addresses may be configured using on-board miniature switches or by host using Hayes AT commands.

## DCD Output

DCD output is FET 30VDC 500mA. In transparent mode, the DCD output is always active. In controlled mode, the DCD output is active when a communications channel has been established with the destination address.  
During communications failure, this output will reset.



9/12 Billabong Street Stafford Qld 4053 Australia

Telephone: +61 7 3352 4533  
Facsimile: +61 7 3352 4577  
email: sales@elpro.com.au  
Internet: www.elpro.com.au

ISO 9001 Certified  
Specifications subject to change without notice.